

The new AN-PSMARM has redefined the mounting industry with its revolutionary design and versatility. This is the only mount of its kind that can offer cable management, 3 pivotal points and 270-degree swivel action. Cables are concealed throughout the arm and lead directly into the wall. In addition to extending almost 23", the arm retracts flush with the wall and virtually disappears behind the screen when folded. The sleek aluminum design makes it the perfect mounting solution on a wall in the bathroom or bedroom, on the end of a kitchen cabinet or any place where full articulation and superior adjustment features are needed. This mount accommodates all 13" – 22" AQUOS Liquid Crystal Televisions.

Features include:

Full Articulation at Three Pivotal Points allows the user to view the LCTV virtually anywhere in the room at any angle. If mounted on the end of a cabinet, the arm can swing all the way around to be viewed from the other side of the room.

GlidePivot Unique Ball Joint design allows the LCTV to tilt up and down providing 70 degrees of tilt action. The ball joint also provides 180 degrees of side-to-side action and a huge 270-degrees of swivel. The ball joint tension is set upon installation and no lubricant is necessary for smooth operation.

CableTrac Cable Management: The only mount of its kind that provides a solution to hide the unsightly cables that are required to operate TVs. The mount utilizes a 2-channel system on the top and bottom of the bracket arms, which allows up to 4 cables to be tucked away within the bracket. The channels extend throughout the arm and a hole concealment is provided to cover the cable entry point into the wall.

Consumer-Friendly Design coordinates with the sleek look and appearance design of AQUOS Liquid Crystal Televisions. This AN-PSMARM itself is sleek and stylish, a welcome contrast to most of the bulky and industrial looking mounts currently available to consumers.

Features & Specifications:

Unit Dimensions: Please refer to diagram on next page
Unit Weight: 4.5 lbs.
Carton Dimensions: 7 7/8" x 2 1/4" x 13 5/8" (w x h x d)
Shipping Weight: 5 lbs.

Maximum Load Capacity: 25 lbs.
Mountable Surfaces: Wood Studs, Concrete, Cabinetry
Compatibility: 13" – 22" AQUOS models
UPC: 074000362109

Dimensions

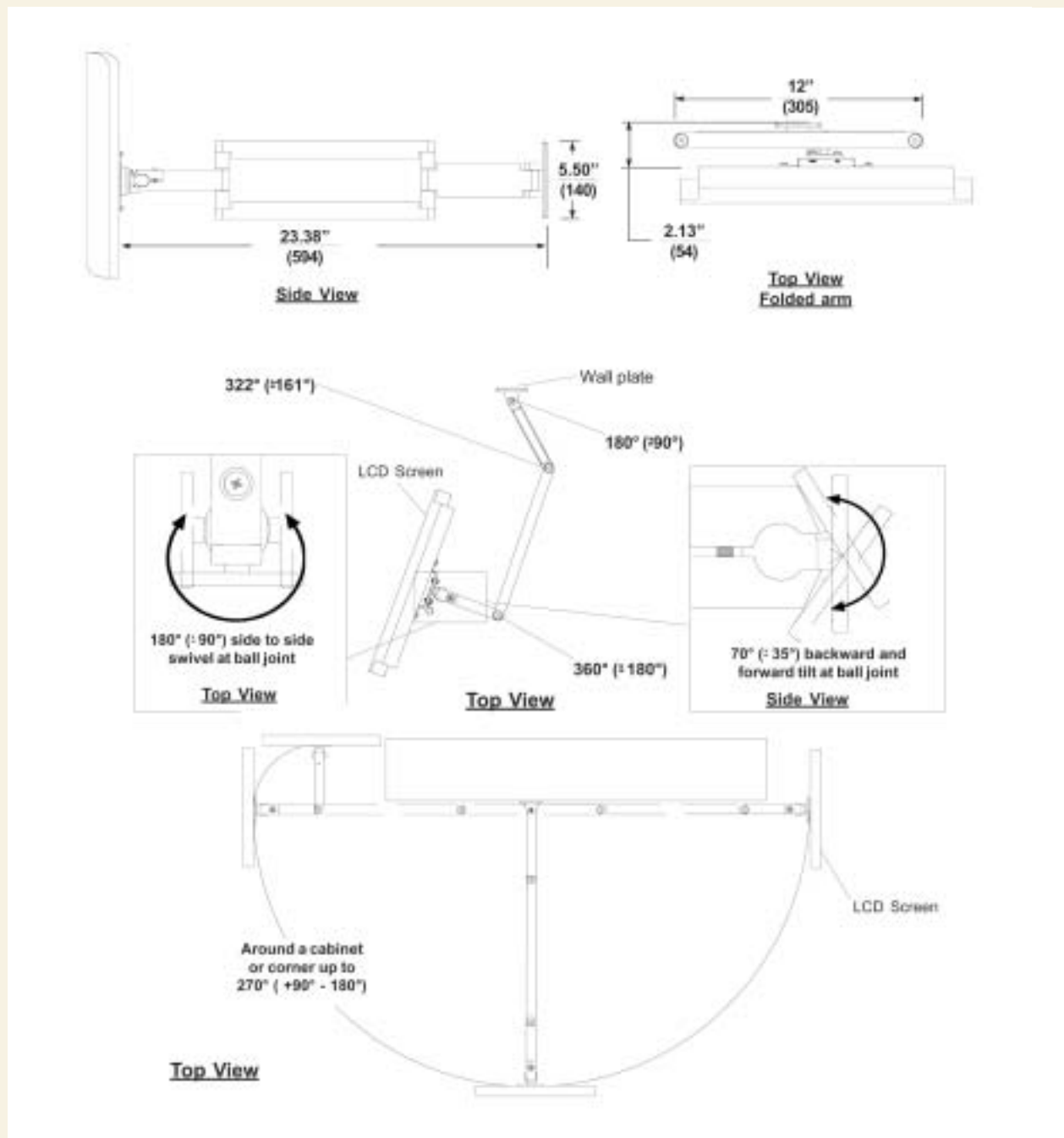

Product specifications and design subject to change without notification.

Manufacturer's Limited Warranty: 5 Year Parts and Labor

See Operation Manual or your dealer for complete details.

TV screen sizes measured diagonally.

Sharp Electronics Corporation

Sharp Plaza, Mahwah, NJ 07430-2135

For more information call: 1-800-BE-SHARP or email at: conlcd@sharpsec.com

www.sharpusa.com

© 2003 Sharp Electronics Corporation SV-02-547/12-08-03

SHARP

..... be sharp